



**Controller  
Indicator  
Transmitter**  
**1/32 DIN - 48 x 24**

**Platinum™  
SERIES**

**C10 line**

User manual • M.I.U.C10-1/02.06 • Cod. J30-478-1AC1 SEA



**ATHENA CONTROLS, INC.**  
5145 Campus Drive  
Plymouth Meeting  
PA 19462 U.S.A.  
Tel: (610) 828-2490  
Fax: (610) 828-7084  
AthenaControls.com



**Controller  
Indicator  
Transmitter**  
**1/32 DIN - 48 x 24**

**C10 line**

---

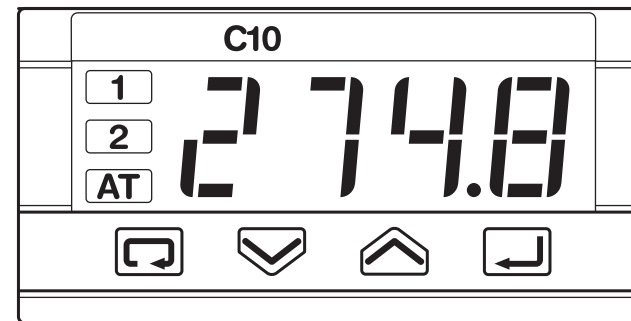



## NOTES

### ON ELECTRIC SAFETY AND ELECTROMAGNETIC COMPATIBILITY.

**Please, read carefully these instructions before proceeding with the installation of the controller.**

**Class II instrument, rear panel mounting.**

This controller has been designed with compliance to:

**Regulations on electrical apparatus** (appliance, systems and installations) according to the European Community directive 73/23 CEE amended by the European Community directive 93/68 CEE and the Regulations on the essential protection requirements in electrical apparatus EN 61010-1 (IEC 1010 - 1) : 90 +A1:92 + A2:95.

**Regulations on Electromagnetic Compatibility** according to the European Community directive n089/336/CEE, amended by the European Community directive n° 92/31/CEE and the following regulations:

Regulations on RF emissions

EN50081 - 1 residential environments

EN50081 - 2 for industrial environments

Regulation on RF immunity

EN500082-2 for industrial equipment and system

**It is important to understand that it's responsibility of the installer to ensure the compliance of the regulations on safety requirements and EMC.**

The device has no user serviceable parts and requires special equipment and specialised engineers. Therefore, a repair can be hardly carried on directly by the user. For this purpose, the manufacturer provides technical assistance and the repair service for its Customers.

Please, contact your nearest Agent for further information.

**All the information and warnings about safety and electromagnetic compatibility are marked with the  sign, at the side of the note.**

# TABLE OF CONTENTS

<b>1</b>	<b>INSTALLATION</b> .....	Page	4
<b>2</b>	<b>ELECTRICAL CONNECTIONS</b> .....	Page	8
<b>3</b>	<b>PRODUCT CODING</b> .....	Page	14
<b>4</b>	<b>OPERATIONS</b> .....	Page	18
<b>5</b>	<b>AUTOMATIC TUNE</b> .....	Page	28
<b>6</b>	<b>TECHNICAL SPECIFICATIONS</b> .....	Page	29

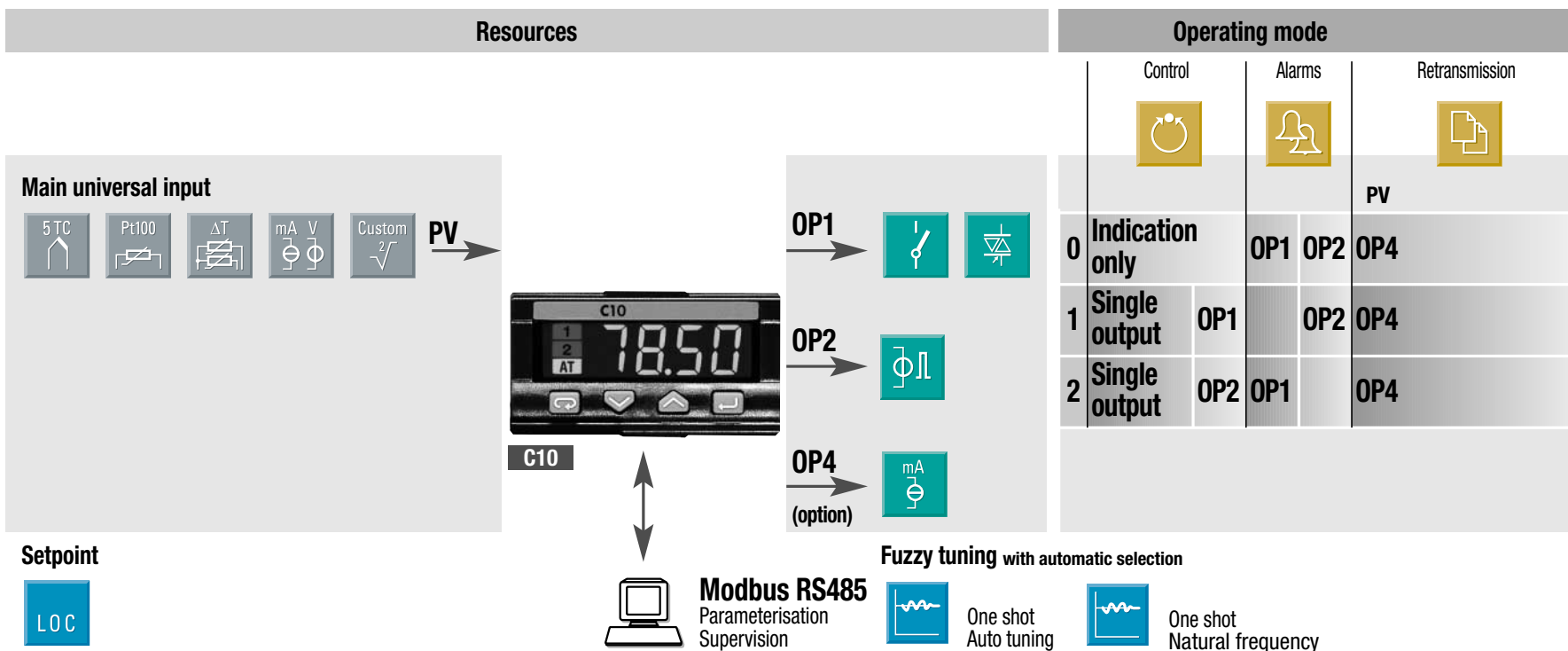

# 1 ■ INSTALLATION

**Installation must only be carried out by qualified personnel.**

Before proceeding with the installation of this controller, follow the instructions illustrated in this manual and, particularly the installation precautions marked with the  symbol, related to the European Community directive on electrical protection and electromagnetic compatibility.



To prevent hands or metal touching parts that may be electrically live, the controllers must be installed in an enclosure and/or in a cubicle.

## 1.1 GENERAL DESCRIPTION

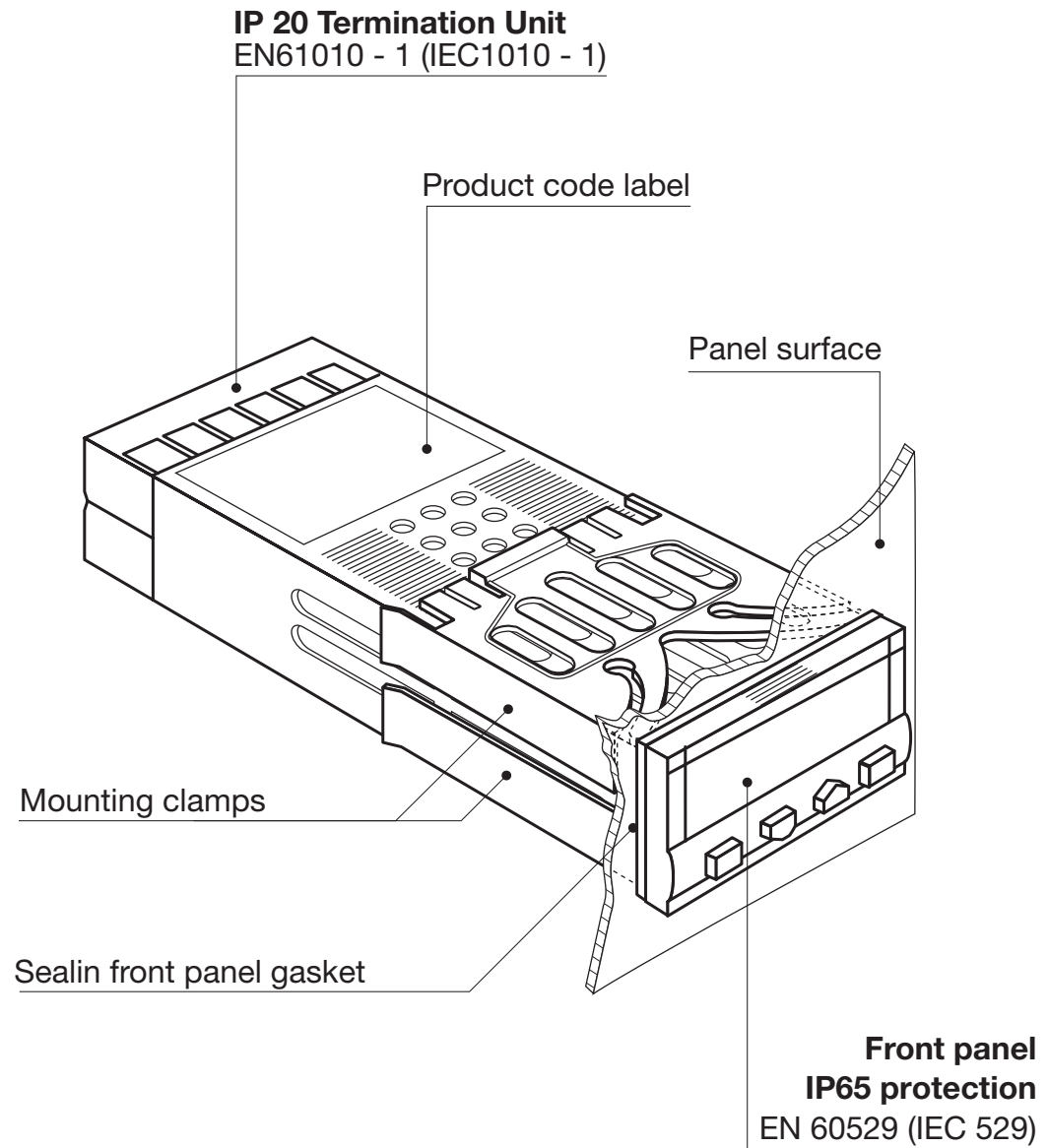

### 1.2 DIMENSIONAL DETAILS

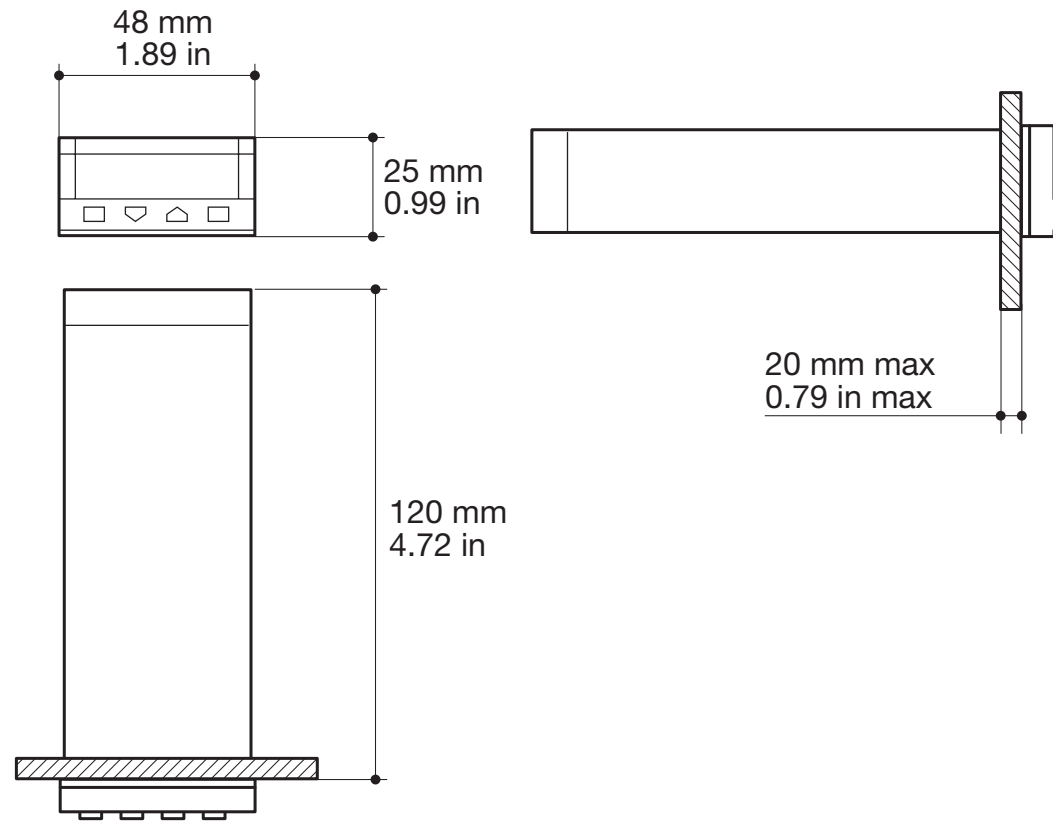

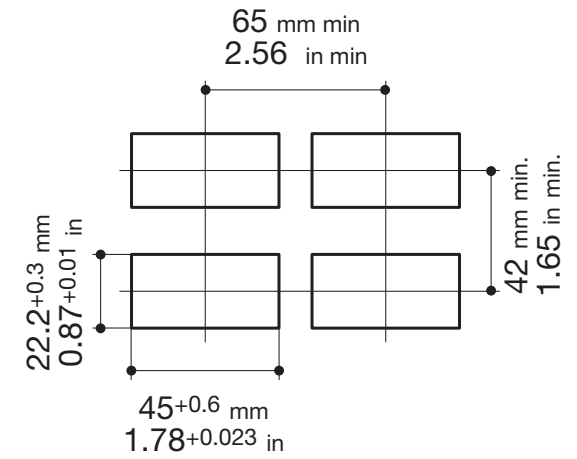

### 1.3 PANEL CUT-OUT





**1.4 ENVIRONMENTAL RATINGS**





**Operating conditions**

 2000	Altitude up to 2000 m
 °C	Temperature 0...50°C
%Rh	Relative humidity 5...95 % non-condensing

<b>Special conditions</b>		Suggestions
 2000	Altitude > 2000 m	Use 24V~ supply version
 °C	Temperature >50°C	Use forced air ventilation
%Rh	Humidity > 95 %	Warm up
	Conducting atmosphere	Use filter

**Forbidden Conditions** 

	Corrosive atmosphere
	Explosive atmosphere

## 1.5 PANEL MOUNTING

### 1.5.1 INSERT THE INSTRUMENT

- 1 Prepare panel cut-out
- 2 Check front panel gasket position
- 3 Insert the instrument through the cut-out

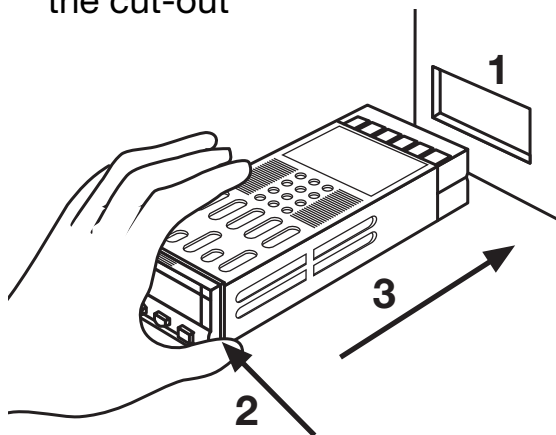

### 1.5.2 INSTALLATION SECURING

- 1 Position the mounting clamps
- 2 Push the mounting clamps towards the panel surface to secure the instrument

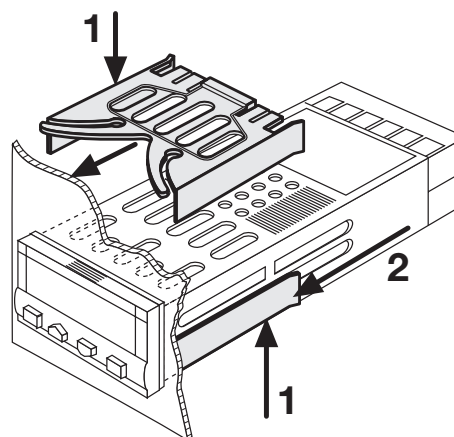

### 1.5.3 CLAMPS REMOVING

- 1 Insert the screwdriver in the clips of the clamps
- 2 Rotate the screwdriver

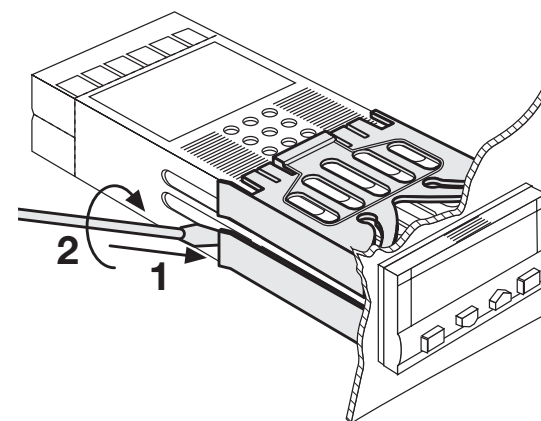

### 1.5.4 INSTRUMENT UNPLUGGING



- 1 Push and
- 2 pull to remove the instrument

Electrostatic discharges can damage the instrument  
Before removing the instrument the operator must discharge himself to ground

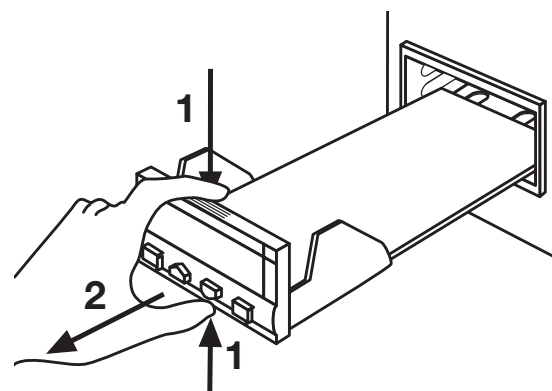

## 2 ELECTRICAL CONNECTIONS

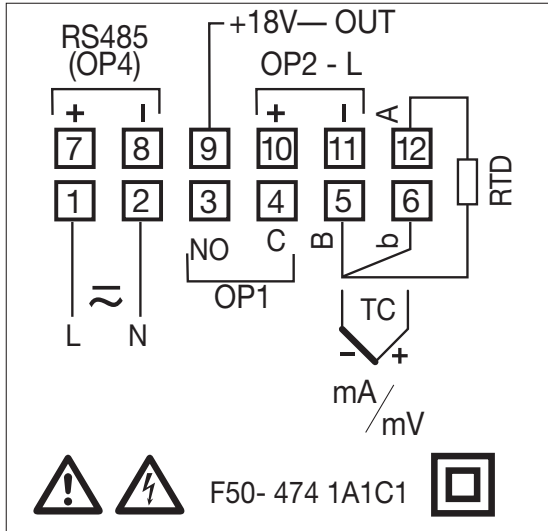

### 2.1 TERMINATION UNIT

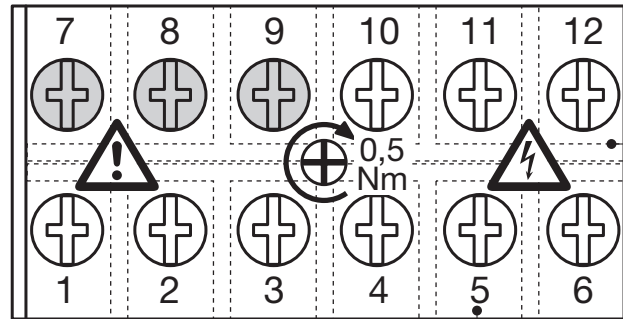

Rear terminal cover

□ 5.7 mm  
0.22 in

Cable size  
0,5...1,5 mm<sup>2</sup>  
(22 a 16 AWG)

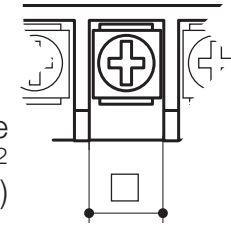

12 screw terminals



Option terminals



Holding screw 0.5 Nm



Positive screw driver PH1



Negative screw driver 0,8 x 4 mm

#### Recommended wire terminal leads

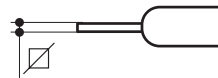

Pin connector  $\varnothing$  1.4 mm - 0.055 in max



Fork-shape AMP 165004  $\varnothing$  5.5 mm - 0.21 in

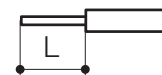

Stripped wire L 5.5 mm - 0.21 in

**PRECAUTIONS**

Despite the fact that the instrument has been designed to work in an harsh and noisy environmental (level IV of the industrial standard IEC 801-4), it is strongly recommended to follow the following suggestions.



All the wiring must comply with the local regulations.

The supply wiring should be routed away from the power cables. Avoid to use electromagnetic contactors, power relays and high power motors nearby.

Avoid power units nearby, especially if controlled in phase angle

Keep the low level sensor input wires away from the power lines and the output cables.

If this is not achievable, use shielded cables on the sensor input, with the shield connected to earth.

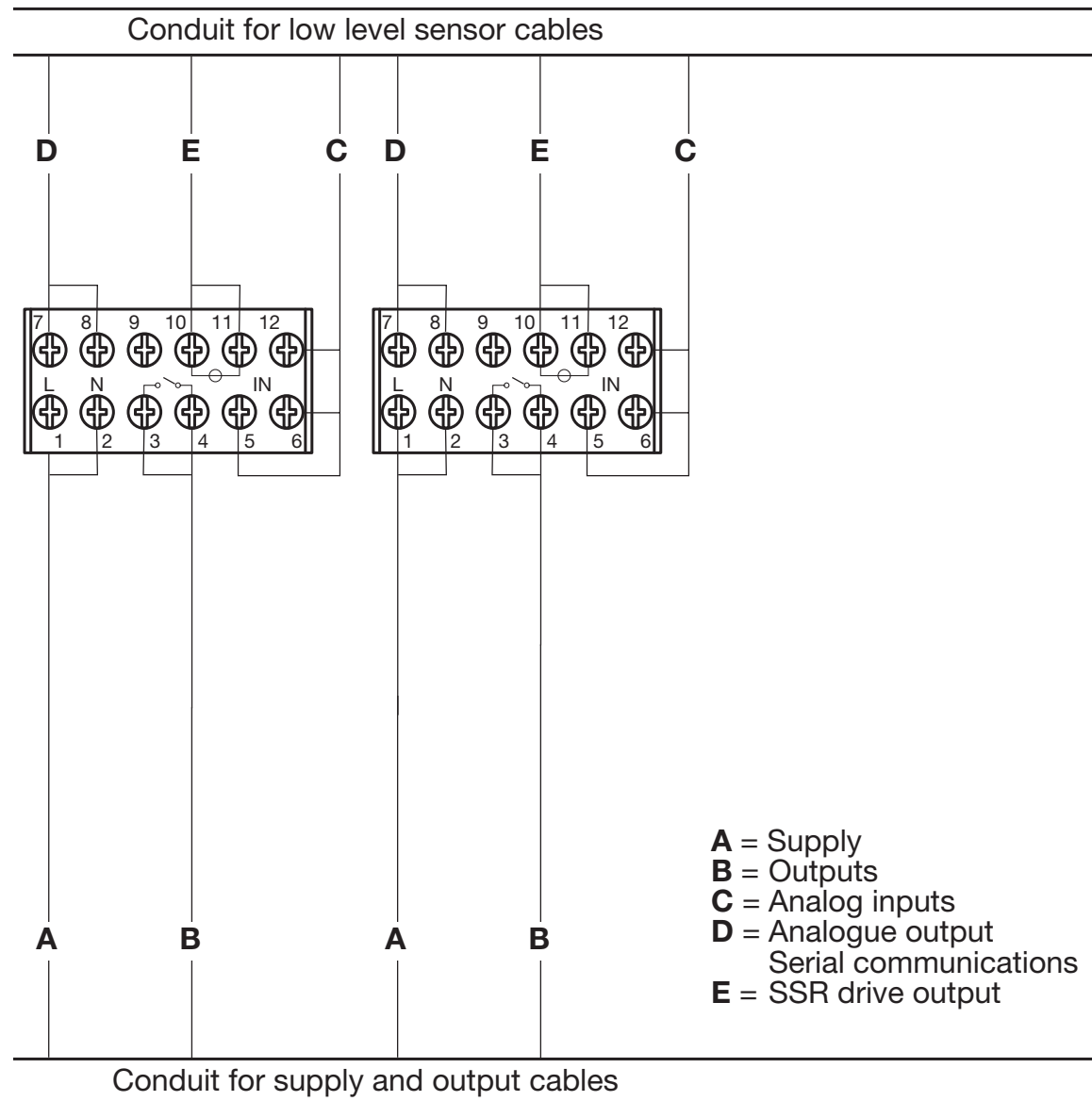
**2.2 RECOMMENDED ROUTING OF WIRES**

### 2.3 TYPICAL INSTRUMENT WIRING

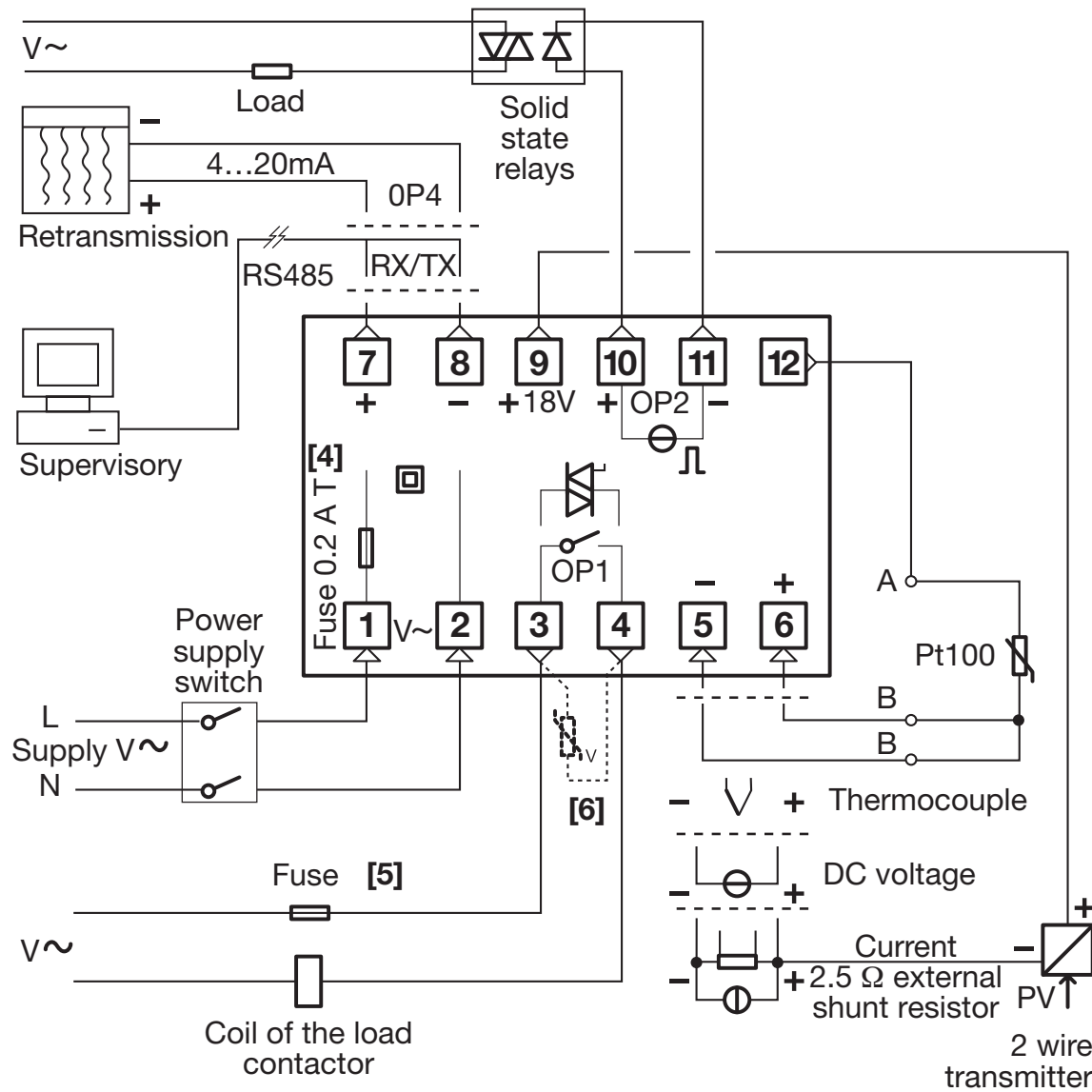

#### Notes:

- 1] Make sure that the power supply voltage is the same indicated on the instrument.
- 2] Switch on the power supply only after that all the electrical connections have been completed.
- 3] In accordance with the safety regulations, the power supply switch shall bring the identification of the relevant instrument. The power supply switch shall be easily accessible from the operator.
- 4] The instrument is protected with a 0.2 A ~ T fuse. In case of failure it is suggested to return the instrument to the manufacturer for repair.
- 5] To protect the instrument internal circuits use:
  - 2 A ~ T fuses for Relay outputs
  - 1 A ~ T fuses for Triac outputs
- 6] Relay contacts are already protected with varistors.  
**Only in case of 24 V ~ inductive loads, use model A51-065-30D7 varistors (on request)**

**2.3.1 POWER SUPPLY**

Switching power supply with multiple isolation and internal fuse

- Standard version:  
nominal voltage:  
100 - 240V $\sim$  (- 15% + 10%)  
Frequency 50/60Hz
- Low Voltage version:  
Nominal voltage:  
24V $\sim$  (- 25% + 12%)  
Frequency 50/60Hz  
or 24V- (- 15% + 25%)
- Power consumption 1.6W max

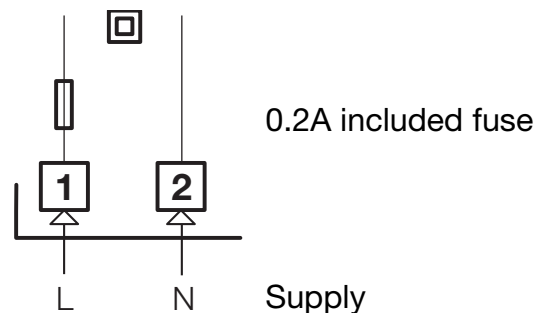
**2.3.2 OP1 OUTPUT****A] Single relay output**

- NO contact for resistive load of up to 2A / 250V $\sim$  max.
- Fuse 2A $\sim$  T (IEC 127)

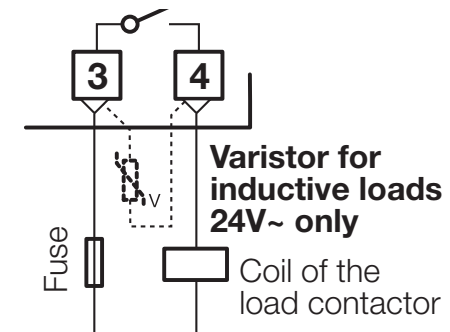
**B] Triac Output**

- NO contact for resistive load of up to 1A / 250V $\sim$  max.
- Fuse 1A $\sim$  T (IEC 127)

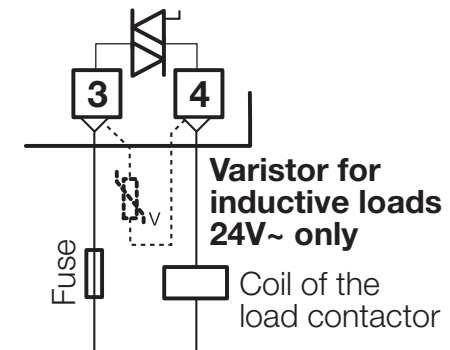
**2.3.3 OP2 OUTPUT**

- Logic output, not isolated  
0...5V-,  $\pm$ 20%, 30mA max

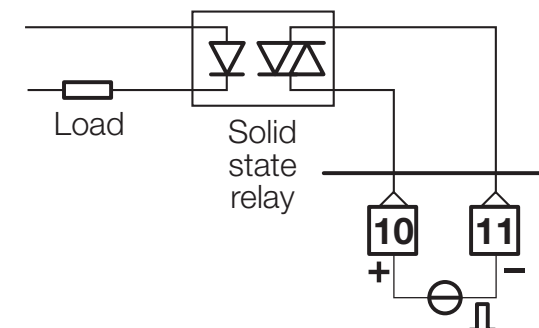

### 2.3.4 PV CONTROL INPUT



- Connect the wires with the polarity as shown
- Use always compensation cable of the correct type for the thermocouple used
- The shield, if present, must be connected to a proper earth.

For L J K S T thermocouple type

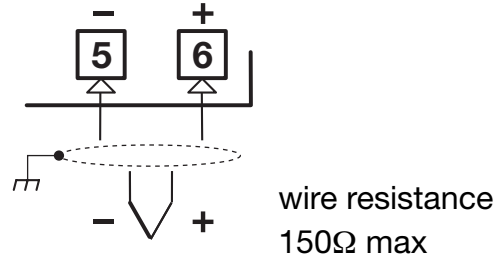

For mA, mV and V

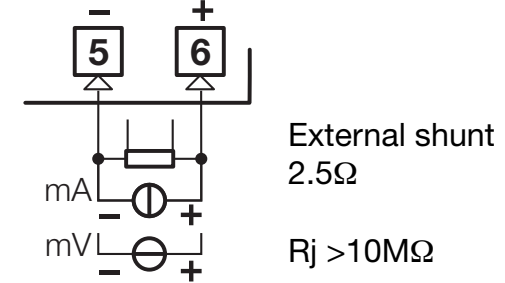

- If a 3 wires system is used, use always cables of the same diameter (1mm<sup>2</sup> min.) (line 20 Ω/lead maximum resistance)
- When using a 2 wires system, use always cables of the same diameter (1,5mm<sup>2</sup> min.) and put a jumper between terminals 5 and 6

For PT100 resistance thermometer

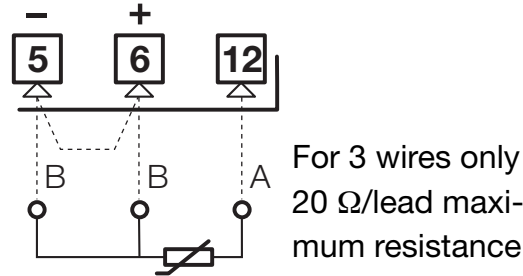

With 2 wire transducer

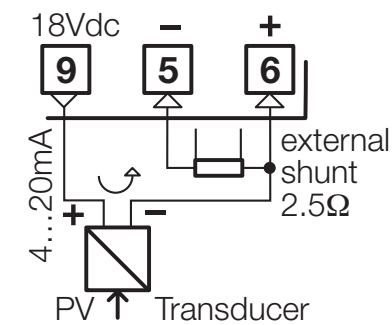

- ⚠ When the distance between the controller and the sensor is 15 mt. using a cable of 1.5 mm<sup>2</sup> diameter, produces an error on the measure of 1°C.

For ΔT (2 x RTD Pt100) Special

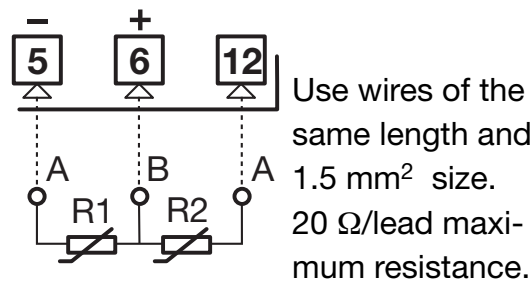

With 3 wire transducer

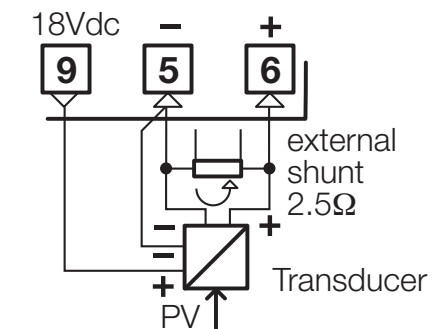

**R1 + R2 must be < 320Ω**

### 2.3.5 OP4 OUTPUT (option)



PV retransmission

- Galvanic isolation  
500V $\sim$ /1 min.
- 0/4...20mA, 750 $\Omega$ / 15V– max

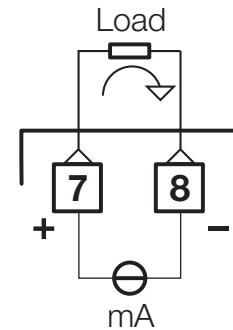

### 2.3.6 SERIAL COMMUNICATIONS (option)



- Galvanic isolation 500V $\sim$ /1 min
- Compliance to the EIA RS485 standard for Modbus/Jbus

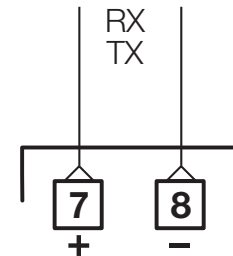

**⚠ Please, read the user instructions on the “C10 controller MODBUS/JBUS protocol”**

# 3 PRODUCT CODING

The complete code is shown on the instrument label. The informations about product coding are accessible from the front panel by mean of a particular procedure described at section 4.2.2 page 19

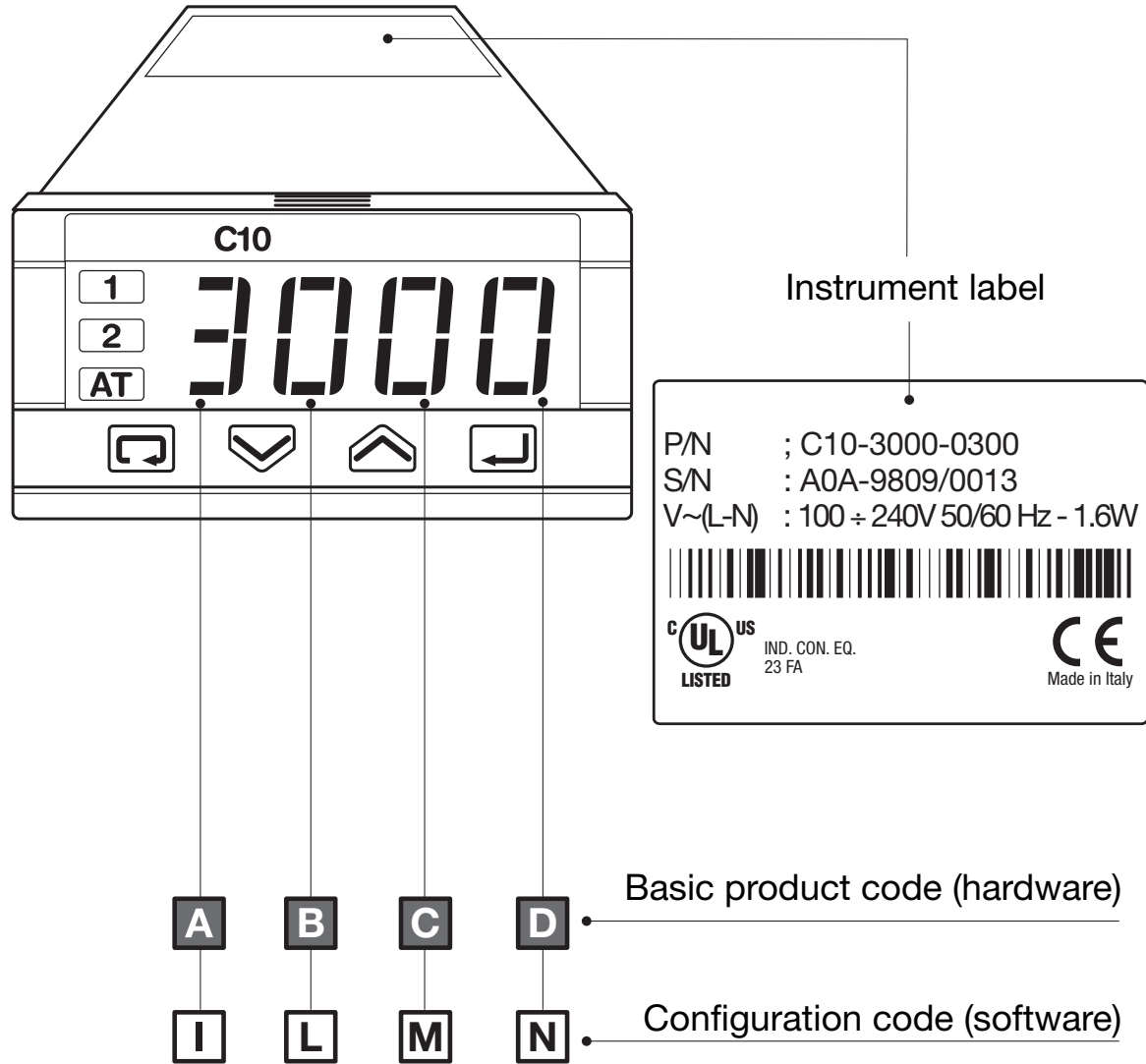

### 3.1 MODEL CODE

The product code indicate the specific hardware configuration of the instrument, that can be modified by specialized engineers only.

Model: **Line** **C 10** **Basic** **A B C D** - **Accessories** **E F G H**

Line	C	10
	C	10

Power supply	A
100 - 240V~ (-15% + 10%)	3
24V~ (-25% + 12%) or 24V- (-15% + 25%)	5

Output 1 [1]	Output 2 [1]	B
Relay	Logic	0
Triac	Logic	3

Option 1	Option 2	C	D
Not provided	Not provided	0	0
	Transmitter Power Supply (PS)	0	6
	Transmitter PS + Retransmission	0	7
RS485 Modbus/Jbus protocol	Not provided	5	0
	Transmitter Power Supply	5	6

Option 3	User manual	E	F
Not provided	Standard English/Spanish manual	0	3

Front Bezel Color [2]	0/4-20mA Input Shunt Resistor [2]	G
Dark Grey (standard)	Standard resistor	0
Beige	Standard resistor	1
Dark Grey	High accuracy resistor	2
Beige	High accuracy resistor	3

Mounting (DIN rail mounting does not include UL)	H
Panel (standard)	0
DIN rail with display	1
DIN rail without display (requires CD option code 50 or 56)	2

#### Notes

[1] Relay SPST N.O. 2A/250V;

Triac 1A/250V; Logic 5V 30mA

[2] Standard shunt resistor without field calibration will provide 1.10% input accuracy for 0/4-20mA input

High accuracy shunt resistor without field calibration will provide 0.20% input accuracy for 0/4-20mA input

Either shunt resistor with field calibration will provide 0.10% input accuracy for 0/4-20mA input

### 3.2 CONFIGURATION CODING

The configuration code consists of 4 digits that identify the operating characteristic of the controller, as chosen by the user.

Section 4.5 at pag. 26 reports the instructions how to set a new configuration code.

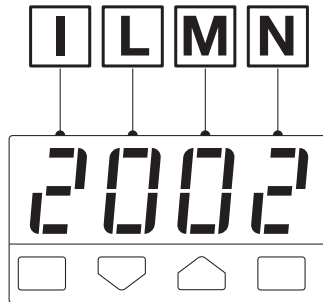

The configuration code can be displayed on the front panel, following the instructions at pag 19 section 4.2.2.

Input type and range			I
TR Pt100 IEC751	-99.9...300.0 °C	-99.9...572.9 °F	0
TR Pt100 IEC751	-200...600 °C	-328...1112 °F	1
TC L Fe-Const DIN43710	0...600 °C	32...1112 °F	2
TC J Fe-Cu45% Ni IEC584	0...600 °C	32...1112 °F	3
TC T Cu-CuNi	-200 ...400 °C	-328...752 °F	4
TC K Cromel -Alumel IEC584	0...1200 °C	32...2192 °F	5
TC S Pt10%Rh-Pt IEC584	0...1600 °C	32...2912 °F	6
DC input 0...50 mV, linear	engineering units [1]		7
DC input 10...50 mV, linear	engineering units [1]		8
Custom input and range			9

Control mode	Output configuration	L
P.I.D.	Control OP1 / alarm AL2 on OP2	0
	Control OP2 / alarm AL2 on OP1	1
On - Off	Control OP1 / alarm AL2 on OP2	2
	Control OP2 / alarm AL2 on OP1	3
2 alarms indicator	Alarm AL1 on OP1/ alarm AL2 on OP2	4
	Alarm AL1 on OP2/ alarm AL2 on OP1	5

Type of control and safety		M
Reverse (AL1 active low)	Safety 0%	0
Direct (AL1 active high)	Safety 0%	1
Reverse (AL1 active low)	Safety 100%	2
Direct (AL1 active high)	Safety 100%	3

**Note**

[1] 0...20 & 4...20mA with provided external 2.5 Ω resistor.



If, when the controller is powered up for the first time, the display shows the following message

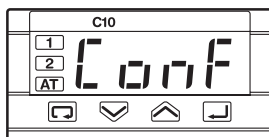

it means that the controller has not been configured yet.

The controller remains in stand-by until the configuration code is set correctly (see chapter 4.6 pag 26).

Alarm 2 type and function		N
Not active		0
Sensor break alarm		1
Absolute	active high	2
	active low	3
Deviation [1]	active high	4
	active low	5
Deviation band [1]	active out (of the band)	6
	active in (the band)	7

#### Note

[1] Choice not available when the controller has been configured as 2 alarms indicator ( L digit assigned to 4 or 5)

# 4 OPERATIONS

## 4.1 KEYPAD COMMANDS AND DISPLAY

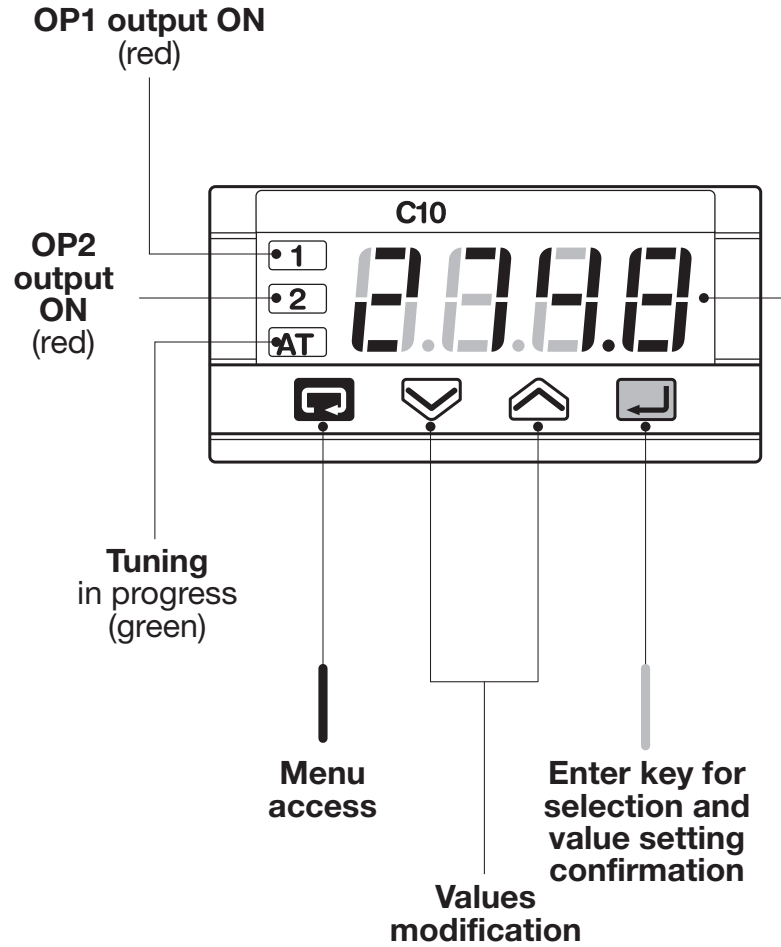

- **PV control input (operator mode)**  
(in engineering units)  
when the measured value is greater than sensor high range

0000

- when the measured value is less than the sensor low range

0000

- **Code and/or value of the Parameter (programming mode)**

## 4.2 DISPLAY

When the display operation is selected, the controller presents automatically all the most important parameters and configuration information.

**During the operation, the parameters values cannot be modified by the user**

After 2 sec from the end of the operation, the controller flashes the display and returns to the normal operating conditions.

### Note

[1] See table page 27

[2] This display is not presented if the instrument has been configured as an On - Off controller

### 4.2.1 OF THE PROCESS VARIABLES

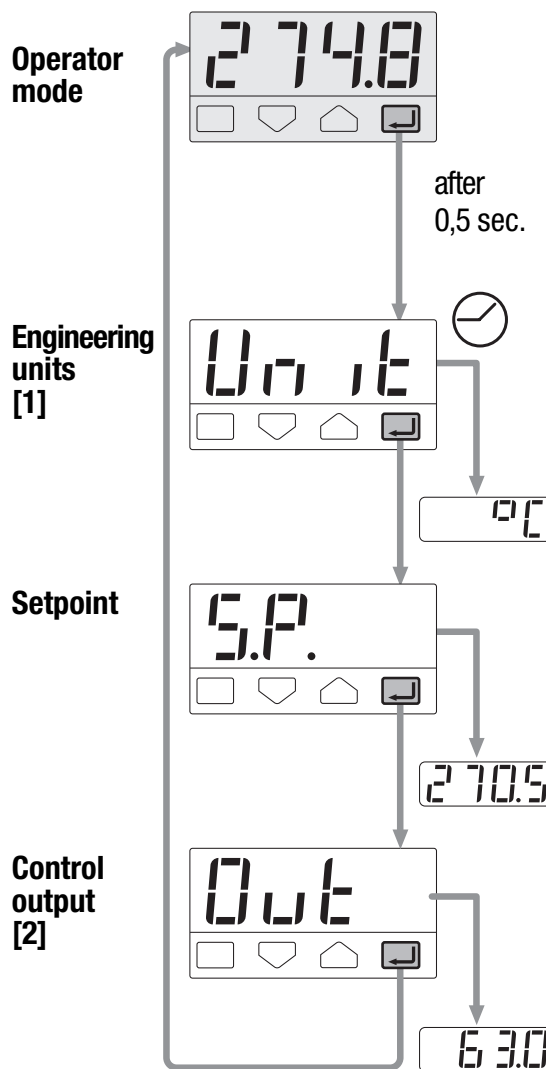

### 4.2.2 OF THE CONFIGURATION CODES

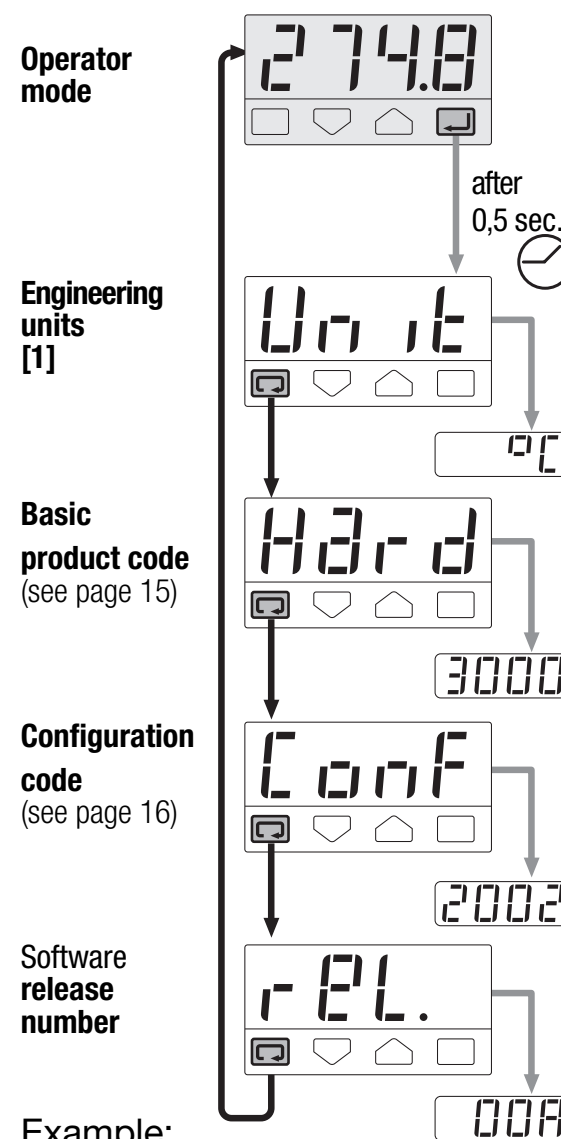



Example:



C10 - 3000 - 2002 / Release 00A

### 4.3 PARAMETER SETTING

#### 4.3.1 NUMERIC ENTRY

(i.e. the modification of the value of a stored Setpoint from 275.0 to 240.0)

Press  or  momentarily to change the value of 1 unit every push



Continued pressing of  or  changes the value, at rate that doubles every second. Releasing the button the rate of change decreases.

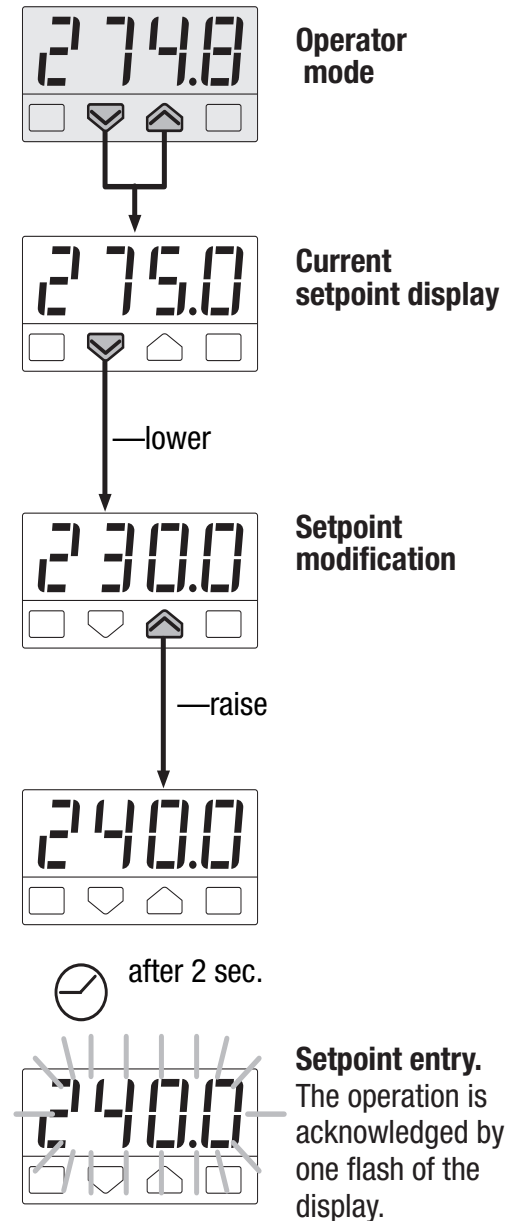

In any case the change of the value stops when it has reached the max/min limit set for the parameter.



### 4.3.2 MNEMONIC CODES SETTING

(e.g. configuration see pages 26, 27)

Press the  or  to display the next or previous mnemonic for the selected parameter.

Continued pressing of  or  will display further mnemonics at a rate of one mnemonic every 0.5 sec. The mnemonic displayed at the time the next parameter is selected, is the one stored in the parameter.

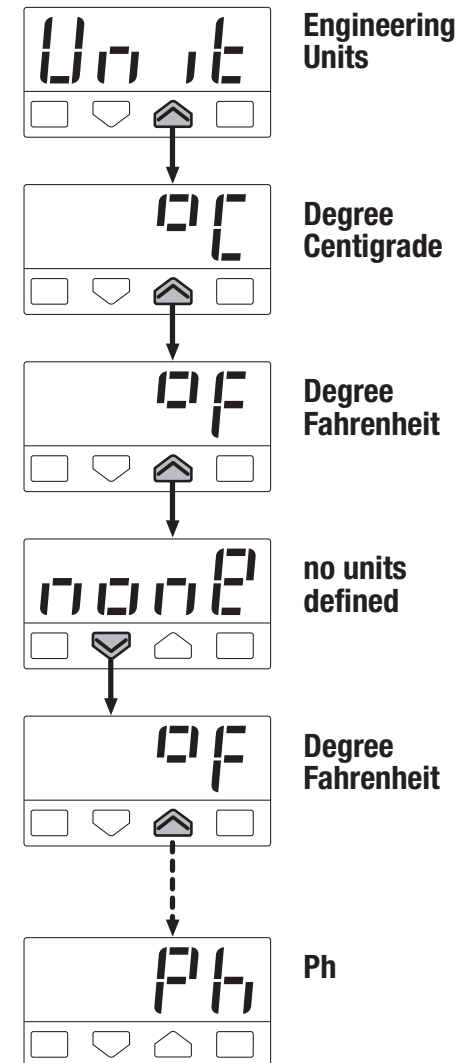

### 4.4 PARAMETER SETTING

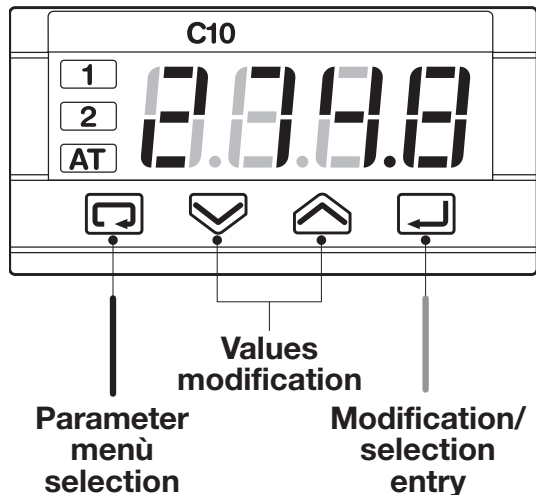

The parameter setting procedure has a timeout. If no keys are pressed for, at least, 30 seconds, the controller switches back, automatically, to the operator mode.

After having selected the parameter or the code, press and to display or modify the value (see pag. 20) The value is entered when the next parameter is selected, by pressing the key.

**Pressing the key, the next group of parameters is presented on the display.**

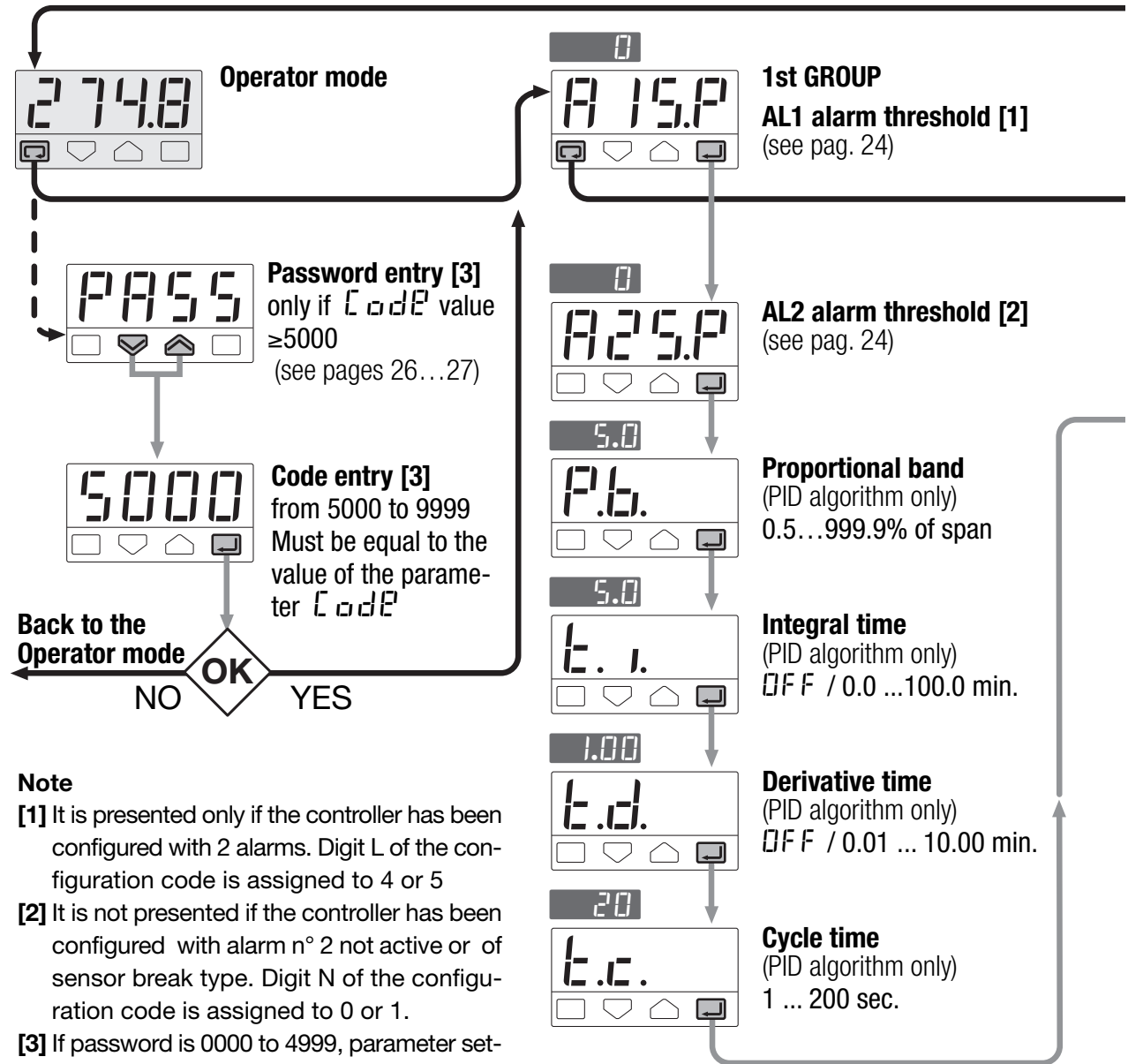

**Note**

- [1] It is presented only if the controller has been configured with 2 alarms. Digit L of the configuration code is assigned to 4 or 5
- [2] It is not presented if the controller has been configured with alarm n° 2 not active or of sensor break type. Digit N of the configuration code is assigned to 0 or 1.
- [3] If password is 0000 to 4999, parameter setting will be available to the operator without entering this password number. If password is 5000 to 9999, parameter setting will only be available by entering this password number.

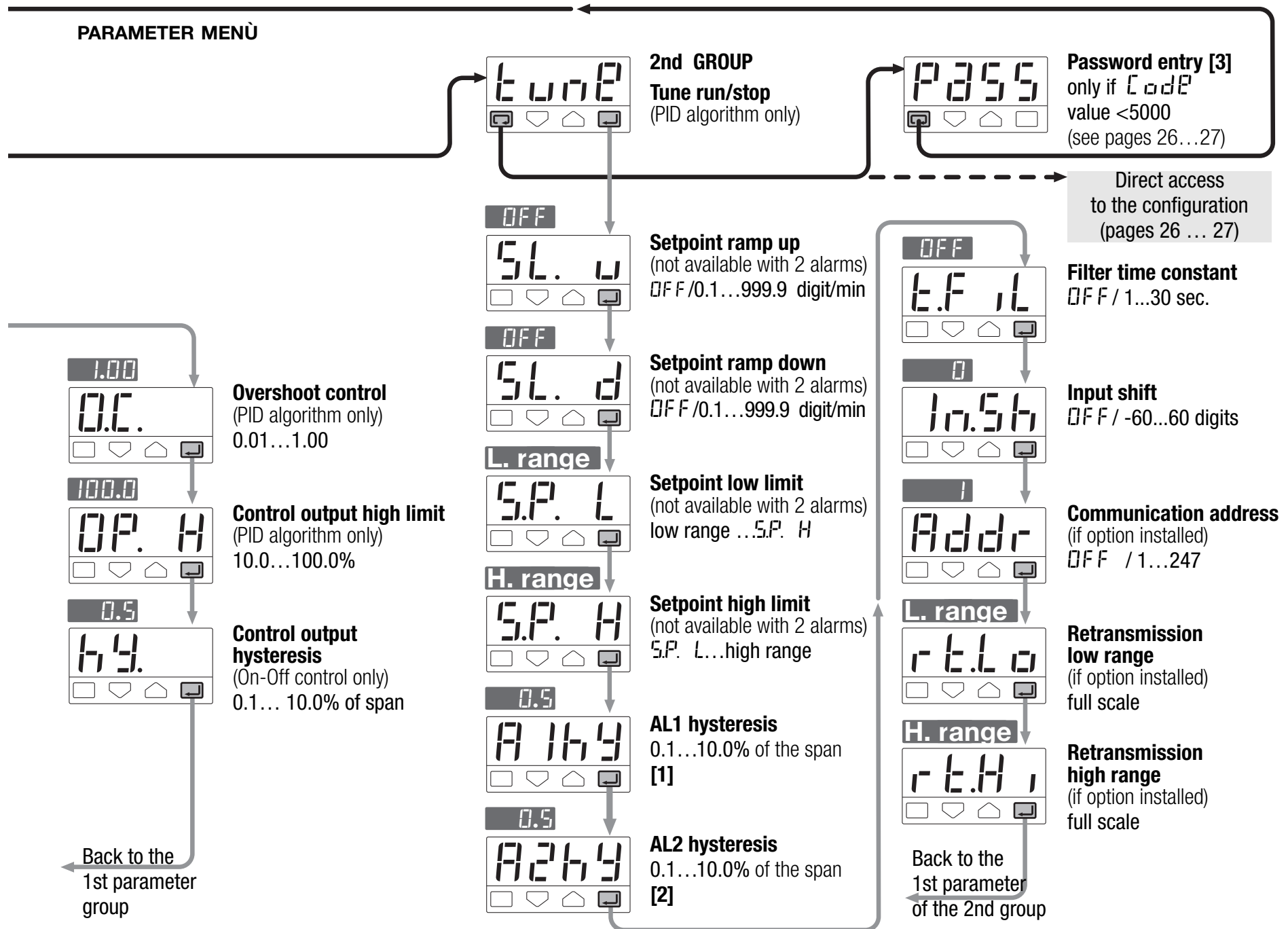

## 4.5 PARAMETER

### 1st GROUP

The controller parameters have been organized in group, according to their functionality area.

#### **A 15.P** AL1 alarm threshold

The threshold is presented only if the controller have been configured with 2 alarms. ( Digit L of the configuration code assigned to 4 or 5)

#### **A 25.P** AL2 alarm threshold

The alarm occurrences handle the OP1 and OP2 outputs, in different ways, according to the configured types of alarms, as illustrated.

#### **P.b.** Proportional band

This parameter specifies the proportional band coefficient that multiplies the error (SP - PV)

#### **I. I.** Integral time

It is the integral time value, that

#### Sensor break or input disconnection

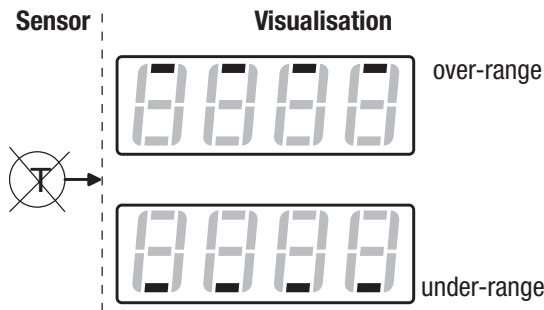

#### Absolute alarm (full scale)

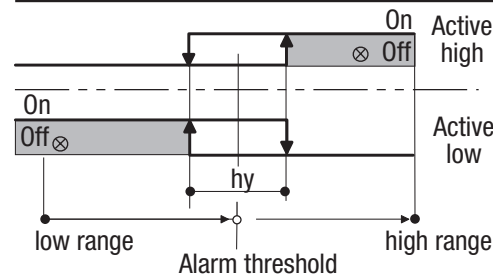

#### Deviation alarm

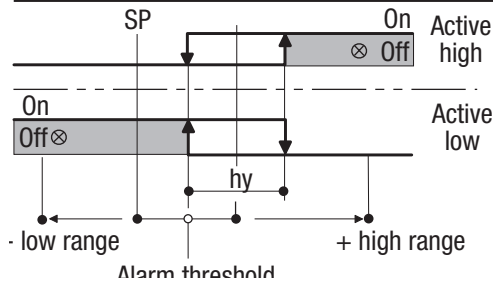

#### Band alarm

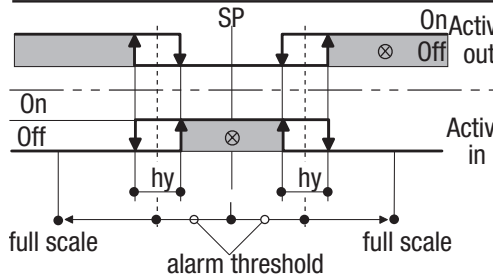

specifies the time required by the integral term to generate an output equivalent to the proportional term. When  $OFF$  the integral term is not included in the control algorithm.

#### **D.d.** Derivative time

It is the derivative term coefficient that specifies the time required by the proportional term P to reach the level of D. When  $OFF$  the derivative term is not included in the control algorithm.

#### **C.c.** Control output cycle time

It's the cycle time of the time proportioning control output. The PID control output is provided through the pulse width modulation of the digital waveform.

#### **O.C.** Overshoot control

This parameter specifies the span of action of the overshoot control. Setting lower values (0.99  $\rightarrow$  0.01) the overshoot generated by a Setpoint change is reduced. The overshoot control doesn't affect the

effectiveness of the PID algorithm. Setting 1, the overshoot control is disabled.

### OP.H Control output high limit

It specifies the maximum value the control output can be set

### HY. Control output hysteresis

#### Hysteresis of the threshold

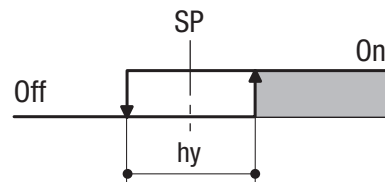

Control output hysteresis span, set in % of the full scale.

## 2nd GROUP

### SL.U Setpoint ramp up

### SL.D Setpoint ramp down

This parameter specifies the maximum rate of change of the Setpoint in digit/min. When the parameter is `OFF`, this function is disabled.

### SP.L Setpoint low limit

Low limit of the setpoint value. When the parameter is `OFF`, this function is disabled.

### SP.H Setpoint high limit

High limit of the setpoint value. When the parameter is `OFF`, this function is disabled.

### AL1 AL1 alarm hysteresis

### AL2 AL2 alarm hysteresis

Hysteresis of the threshold of both the alarms, that activate OP1 and OP2 control output. It is specified as a % of the full scale.

### EF.L Input filter time constant

Time constant, in seconds, of the RC input filter applied to the PV input. When this parameter is set to `OFF` the filter is bypassed.

#### Filter response

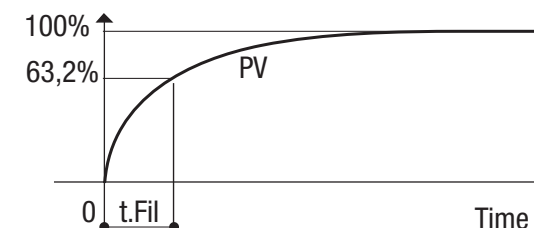

### In.Sh Input shift

This value is added to the measured PV input value. Its effect is to shift the whole PV scale of up to  $\pm 60$  digits.

### Addr Controller address

the address range is from 1 to 247 and must be unique for each controller on the communication bus to the supervisor. When set to `OFF` the controller is not communicating

### re.Lo Retransmission low range

### re.Hi Retransmission high range

These parameters define the range of the OP4 retransmission output. Example: 4..20 mA output corresponding to 20...120°C.

## 4.6 CONFIGURATION

The configuration of the controller is specified through a 4 digit code that defines the type of input, of control output and of the alarms. (sect. 3.2 pag16)

Other parameters specify the type of auxiliary functions.

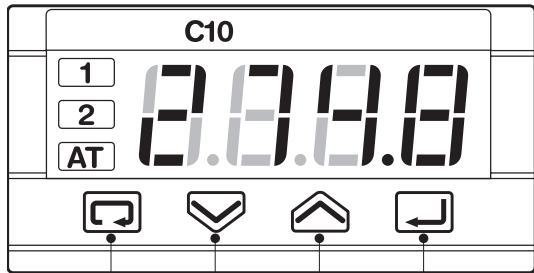

Parameter menu selection

Values modification

Modification/selection entry

Press or to display the next parameter or the next code and change its value.

The new value entered is stored into the controller when the next parameter is selected by pressing .

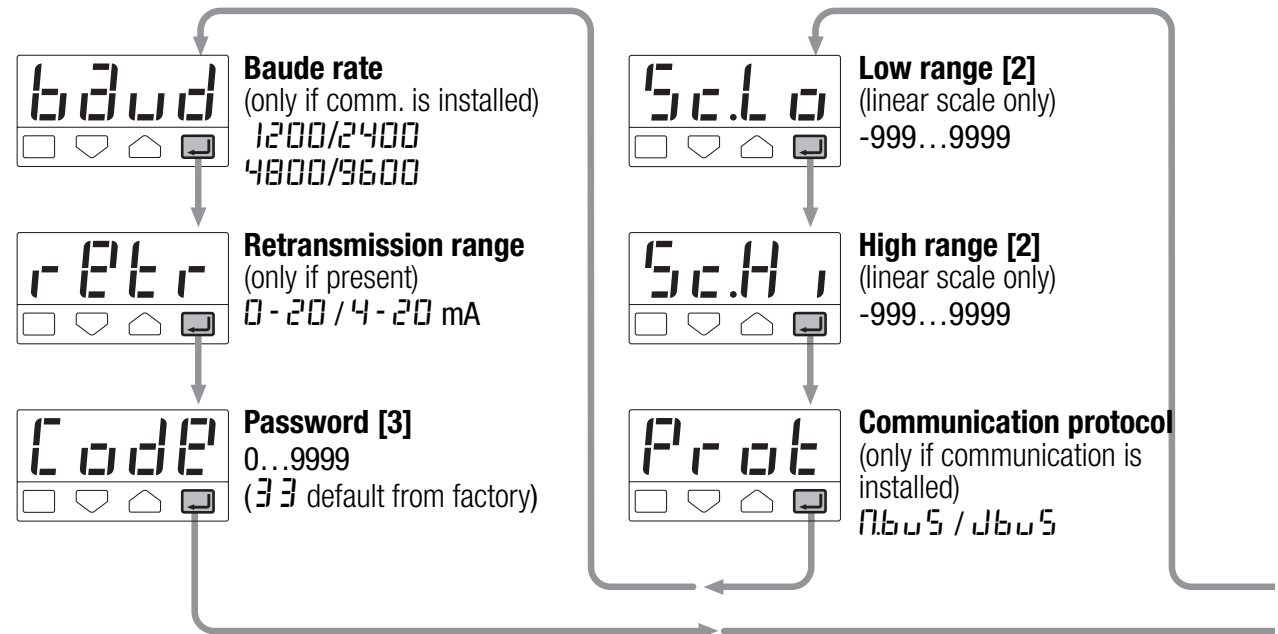
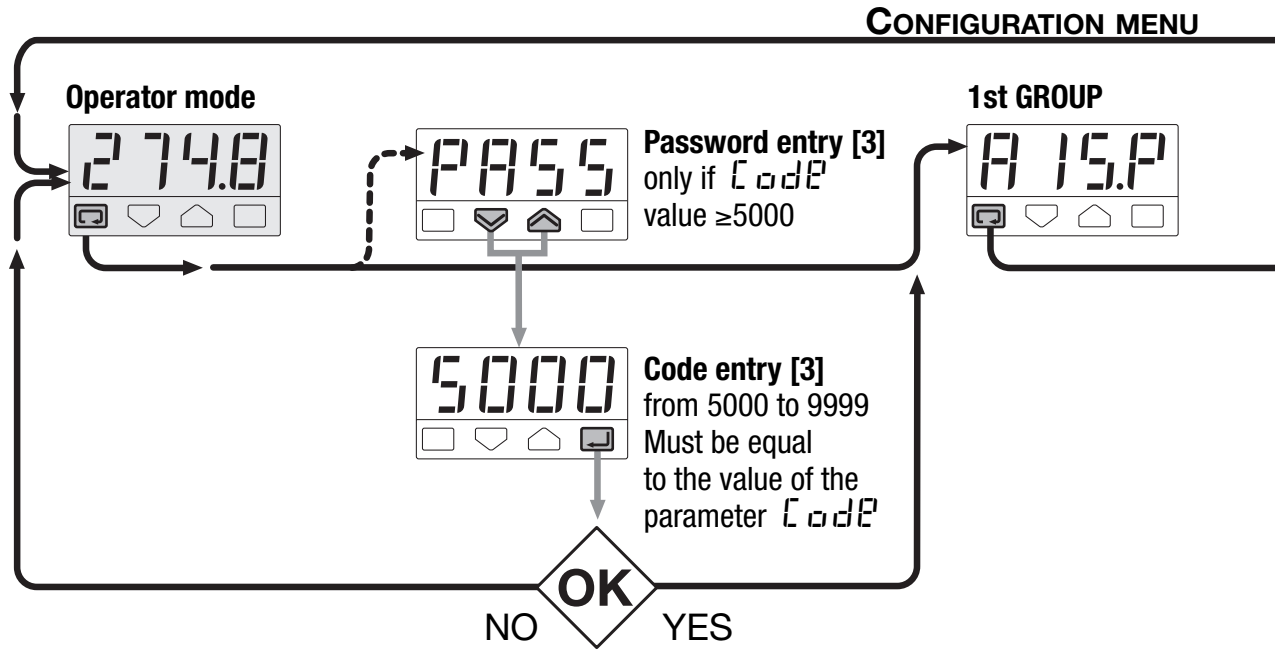

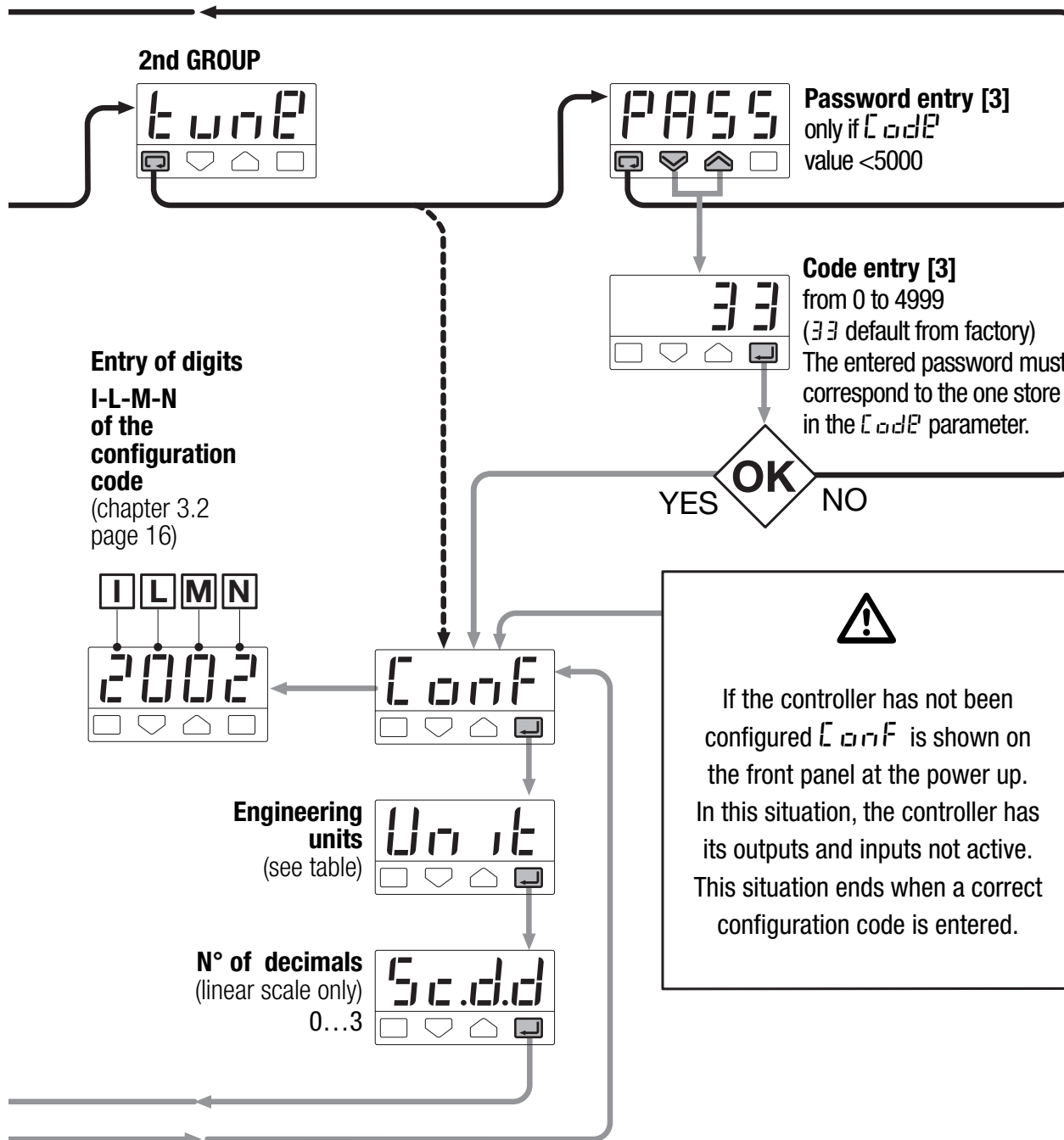

**Note**

Pressing the the next group of parameters is displayed.

[1] Table of the supported Engineering Units.

Centigrade degrees *	°C
Fahrenheit degrees *	°F
none	none
mV	mV
Volt	V
mA	mA
Ampere	A
Bar	bar
PSI	PSI
Rh	rh
pH	pH

\* For inputs from thermocouple or resistance thermometer, the choice is between °C and °F only.

[2] Range of min 100 digits.

[3] If password is 0000 to 4999, parameter setting will be available to the operator without entering this password number. If password is 5000 to 9999, parameter setting will only be available by entering this password number.

# 5 AUTOMATIC TUNE

**Start/stop of the Fuzzy Tuning**  
The Tuning operation can be started or stopped any time.

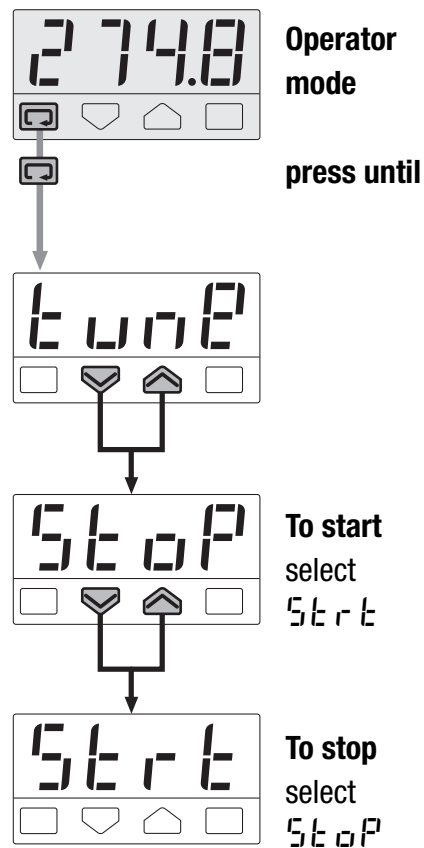

The green led **AT** goes on when the Fuzzy Tuning is in progress. At the end of this operation, the calculated PID terms parameter are stored and used by the control algorithm and the controller goes back to the operator mode. The green led **AT** becomes off.

This function allows the calculation of the optimal PID terms parameters, monitoring the response of the process to disturbances. The controller provides 2 types of “one shot” tuning algorithm, that are selected automatically according to the process condition when the operation is started.

### Step response

This type is selected when, at the start of the autotune operation, the PV is far from the Setpoint of more than 5% of the span. This method has the big advantage of fast calculation, with a reasonable accuracy in the term calculation.

### Natural frequency

This type is selected when the PV is close to the SP setpoint.

This method has the advantage of a better accuracy in the term calculation with a reasonable speed calculation.

**The Fuzzy Tuning determines automatically the best method to use to calculate the PID term, according the process conditions.**

### Step response

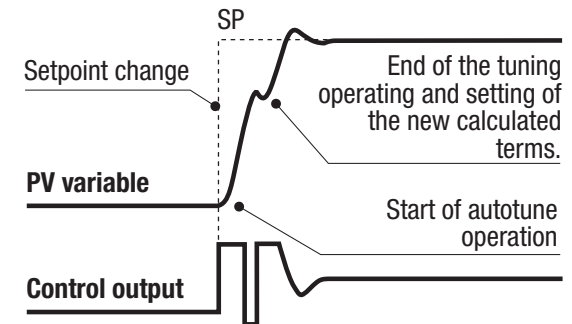

### Natural frequency

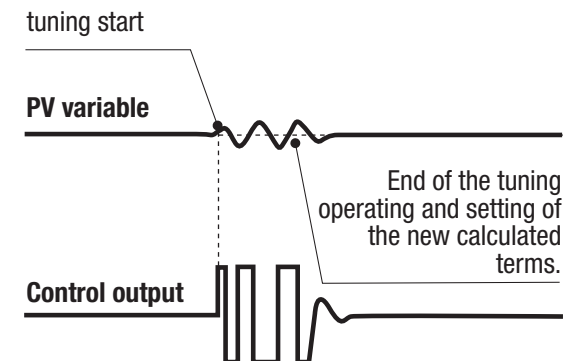

# 6 TECHNICAL SPECIFICATIONS

<b>Features</b> (at 25°C enviromental temp.)	<b>Description</b>			
<b>Total configurability</b> see par. 3.2 pag. 16 par. 4.6 pag. 26	From keypad or serial communication the user selects: the type of input - the associated functions and the corresponding outputs - the type of control algorithm - the type of output and the safe conditions - the type and functionality of the alarms - the values of all the control parameters.			
<b>PV Input</b> (see pag.12 and pag. 16)	Common characteristics	A/D converter with resolution of 50.000 points Update measurement time: 0.2 seconds Sampling time: 0.5 seconds Input bias: - 60...+ 60 digit Input filter with enable/disable: 1...30 seconds		
	Accuracy	0.25% ± 1 digits for temperature sensors 0.1% ±1 digits (for mV) 0.1% ±1 digits + accuracy of the used external shunt resistor (for mA)	Between 100...240V~ the error is minimal	
	Resistance thermometer	Pt100Ω at 0°C (IEC 751)  °C/°Fselectable	2 or 3 wires connection	Max. wire Res.: 20Ω max (3 wires) Input drift: 0.3°C/10°C Env.Temp. <0.1°C / 10Ω Wire Res.
	Thermocouple	L,J,T,K,S (IEC 584)  °C/°F selectable	Internal cold junction compensation in °C/°F	Max. wire Res.: 150Ω max Input drift: <2μV/°C Env. Temp. <0.5μV / 10Ω Wire Res.
	DC input (current)	4...20mA,0-20mA with external shunt 2.5Ω	Engineering units Conf. decimal point position	Input drift: <0.1% / 20°C Env. temp.
	DC input (voltage)	Rj >10MΩ 10...50mV, 0-50mV Rj >10MΩ	Init. Sc. -999...9999 Full Sc. -999...9999 (min. range of 100 digits)	

































<b>Features</b> (at 25°C enviromental temp.)	<b>Description</b>				
<b>Operating mode and Outputs</b>	Indicator with 2 alarms	<b>AL1 alarm</b>		<b>AL2 alarm</b>	
		OP1 - Relay or Triac	OP2 - Logic		
	OP2 - Logic	OP1 - Relay or Triac			
	1 PID loop or 1 ON-OFF loop with 1 Alarm	<b>Control output</b>		<b>AL2 alarm</b>	
		OP1 - Relay or Triac	OP2 - Logic		
		OP2 - Logic	OP1 - Relay or Triac		
<b>Control Mode</b>	Algorithm		PID with overshoot control or ON OFF		
	Proportional band (P)		0.5...999.9%		
	Integral time (I)		0.1...100.0 min	Off = 0	
	Derivative time (D)		0.01...10.00 min		
	Cycle time		1...200 sec		
	Overshoot control		0.01...1.00		
	High limit		100.0...10.0%		
	Hysteresis		0.1...10.0%	ON-OFF algorithm	
<b>OP1 output</b>	SPST Relay N.O., 2A/250V~ for resistive load Triac, 1A/250V~ for resistive load				
<b>OP2 output</b>	Logic, not isolated: 5V-, ± 10%, 30mA max				
<b>AL1 alarm</b> (indicator with 2 alarms)	Hysteresis 0.1...10,0% full scale				
	Active high		Absolute threshold, whole range		
	Active low				
<b>AL2 alarm</b>	Hysteresis 0.1...10,0% c.s.				
	Action	Active high	Action type	Deviation threshold ±range	
		Active low		Band threshold 0...range	
		Special function		Absolute threshold whole range	
Special function	Sensor break				

<b>Features</b> (at 25°C enviromental temp.)	<b>Description</b>	
<b>Setpoint</b>	Ramp up and down	0.1...999.9 digit/min (Off = 0)
	Low limit	From low range to the high limit
	High limit	From low limit to the high range
<b>OP4 PV retransmission</b> (option)	Galvanic isolation: 500 V $\sim$ /1 min Resolution 12bit (0.025%) Accuracy: 0.1 %	Current output: 0/4...20mA 750 $\Omega$ /15V max
<b>One shot Fuzzy-Tuning</b> with automatic selection	The controller selects automatically the best method according to the process conditions	Step response
		Natural frequency
<b>Serial comm.</b> (option)	RS485 isolated, Modbus/Jbus protocol, 1200, 2400, 4800, 9600 bit/sec 2 wires	
<b>Auxiliary Supply</b>	+18V– $\pm$ 20%, 30mA max for an external transmitter supply	
<b>Operational safety</b>	Measure input	Detection of out of range, short circuit or sensor break with automatic activation of the safety strategies and alerts on display
	Control output	Safety value: 0...+100%. (user enabled/disabled)
	Parameters	parameter and configuration data are stored in a non volatile memory for an unlimited time
	Access protection	Password to access the configuration and parameters data
<b>General characteristics</b>	Power supply	100 - 240V $\sim$ (- 15% + 10%) 50/60Hz or 24V $\sim$ (- 25% + 12%) 50/60Hz and 24V– (- 15% + 25%) Power consumption 1.6W max
	Electric safety	Compliance to EN61010, installation class 2 (2500V) pollution class 2
	Electromagnetic compatibility	Compliance to the CE standards for industrial system and equipment
	Approvals	UL, cUL
	Protection EN650529	IP20 termination unit IP65 front panel
	Dimensions	1/32 DIN - 48 x 24, depth 120 mm, weight 100 gr. apx.

## ■ WARRANTY

We warrant that the products will be free from defects in material and workmanship for 3 years from the date of delivery. The warranty above shall not apply for any failure caused by the use of the product not in line with the instructions reported on this manual.

# ICONS TABLE

Main universal input		Digital input	Digital input connected functions
 Thermocouple	 Isolated contact	 Auto/Manual	
 RTD (Pt100)	 NPN open collector	 Run, Hold, Reset and program selection	
 Delta Temp (2x RTD)	 TTL open collector	 PV hold	
 mA and mV		 Setpoint slopes inhibition	
 Custom	<b>Setpoint</b>		
 Frequency	 Local	<b>Output</b>	
	 Stand-by	 SPST Relay	
<b>Auxiliary input</b>		 Keypad lock	 Triac
 Current transformer	 Outputs lock	 SPDT Relay	
 mA Remote setpoint	 Start-up function	 mA	
 Volt Remote setpoint	 Timer function	 mA mV	
 Feedback potentiometer	 Memorized	 Logic	
	 Remote		
	 Setpoint programmer		