

**Melt Pressure Gauge or Transmitter with Visual Indication**  
**Models RTG & CTG**  
**with 4-20 mA or 0-10 Vdc output.**  
**Installation & Operating Manual Version 1.00**

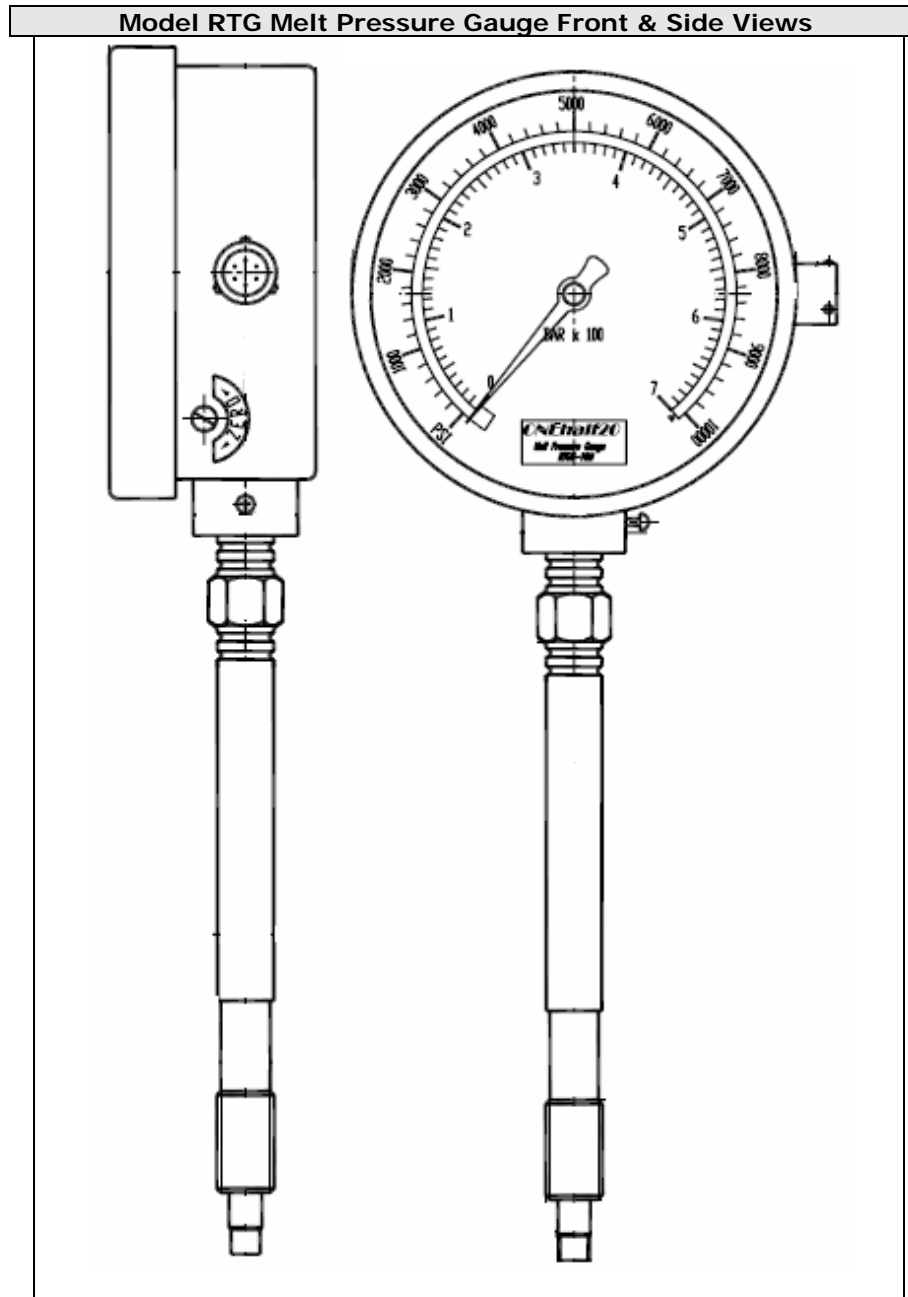



### Before Proceeding

Check to insure that the model number of the ONEhalf20 Melt Pressure Gauge is suitable for your application. ONEhalf20 Melt Pressure Gauges are available in two (2) unique designs. The RTG style (first 3 letters of the model number) is a rigid stem only version of the Melt Pressure Gauge, or the CTG style which also has a rigid stem but additionally incorporates 18" of flexible capillary. The next designation is a numeric number indicating the rigid stem length in inches. This is followed by the output designation "MA" (4-20 mA) or "V" (0-10 Vdc). This is then followed by the pressure range designation i.e. (-10M = 0-10,000 psi). If you are unsure please consult [www.onehalf20.com](http://www.onehalf20.com).

### Quality & Conformity

Your ONEhalf20 Melt Pressure Gauge comes complete with a certificate of quality and conformity. This certificate includes detailed information regarding the specific accuracy, non-linearity, hysteresis, and repeatability of your Melt Pressure Gauge. Please refer to this certificate for detailed product information. Your ONEhalf20 Melt Pressure Gauge is fully compatible with all Melt Pressure Transmitters incorporating the Bendix style 6 pin bayonet connector. Also included is a Transducer Care Guide. Please refer to this information to insure that your ONEhalf20 Melt Pressure Gauge provides years of reliable trouble free service.

### Operating Principle

ONEhalf20 Melt Pressure Gauges with transmitter output (designation "MA" or "V") are used to make pressure measurements of molten polymers up to 750 degrees F (400C). These Melt Pressure Gauges incorporate a four-arm, 350-Ohm, bonded foil Wheatstone bridge strain gage. An amplifier is added to this proven technology to provide a high-level output signal, (0 - 10 VDC, or 4 - 20 mA). The Gauge is designed to provide an output which is proportional to the melt pressure, in addition to providing an analogue indication of melt pressure. These Gauges also include an internal shunt calibration feature ("R-Cal") that is used to simulate a signal of 80% of full scale output. This eliminates the need for a calibrated pressure source when scaling associated instrumentation.

### Installation

Do not remove protective cap covering Gauge threads until ready to install. Prior to initial installation, verify correct machining of the 1/2-20UNF mounting hole. Detailed mounting hole information is available at [www.onehalf20.com](http://www.onehalf20.com) (under the technical section). When reinstalling make sure that the mounting hole is clear of material. A ONEhalf20 Cleaning Tool Kit, (CLEANKIT-1/2-20), should be used.

To prevent galling, lightly coat Gauge threads with a high temperature anti-seize material. An adequate seal, in a properly machined and maintained mounting well, is obtained with 100 in-lbs (8.3 ft-lbs) mounting torque. Maximum recommended torque is 500 in-lbs (41.6 ft-lbs). The electronics housing should be secured, in an area where the ambient temperature will not exceed 160 F (70C).

[www.onehalf20.com](http://www.onehalf20.com)

Tel: (416) 781-1881

Fax: (416) 781-0940

**Mounting Hole (1/2-20 UNF 2B)**

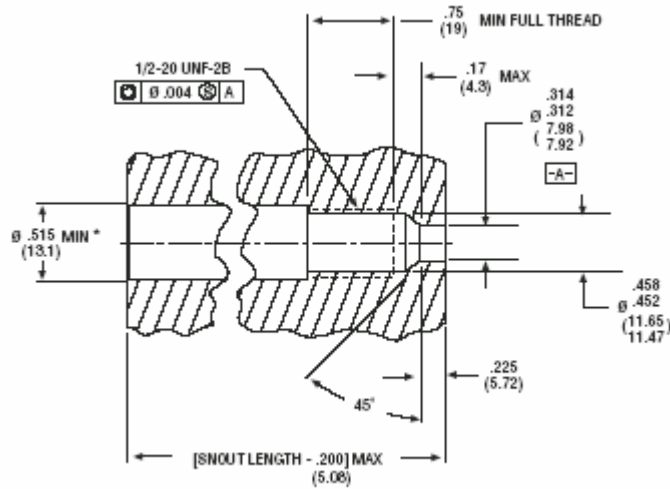

**Mounting Hole (M18 X 1.5)**

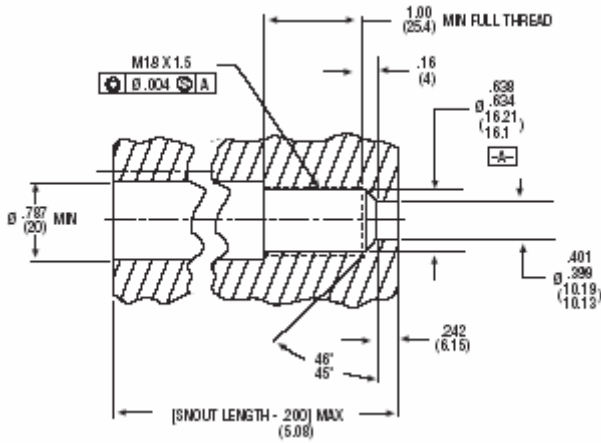

**Wiring**

The standard electrical termination on this series is a 6-pin connector, Bendix PT02A-10-6P (or equivalent). A mating plug, Bendix PT06A-10-6S (SR) (or equivalent), is required or can be part of the appropriate ONEhalf20 cable assembly. Models with output designation "MA" provide an output of 4-20 mA and output designation "V" provide an output of 0-10 Vdc. Recommended excitation voltage for a ONEhalf20 Melt Pressure Gauge is 24 Vdc.

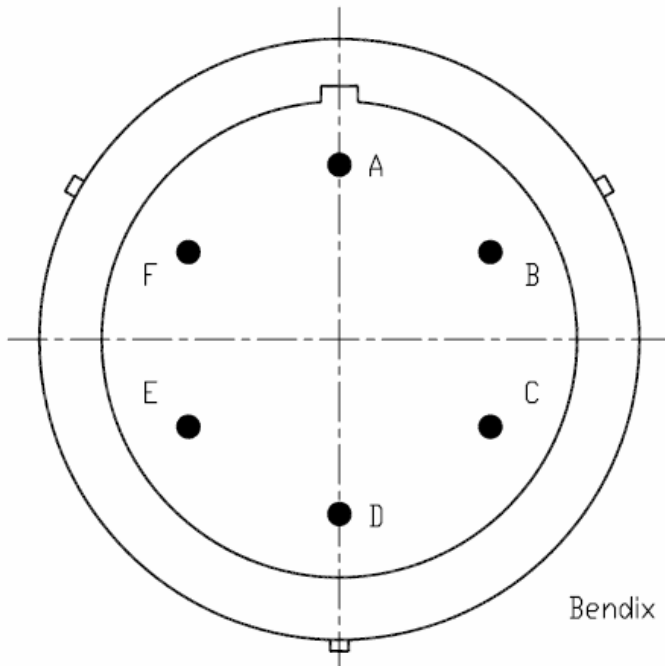

Bendix PT02-10-6P or Equivalent

	mA Output (Excitation-24Vdc)	Volt Output (Excitation-24Vdc)
Pin A/Red	Input/Signal(+)	Signal(+)
Pin B/Black	Input/Signal(-)	Signal(-)
Pin C/White	No Connection	Excitation(+)
Pin D/Green	No Connection	Excitation(-)
Pin E/Blue	Calibration 1	Calibration 1
Pin F/Orange	Calibration 2	Calibration 2

### Start-Up

Bring system to operating temperature and, with no pressure, adjust the ZERO balance potentiometer, located under the seal screw on Gauge housing until output is 0 Vdc or 4 mA, depending on model. Next, short the leads from the "R-Cal", pins E and F, and adjust the SPAN potentiometer until the output is 80% of full scale, i.e. (8 Vdc for "V" output transmitters or 16.8 mA for "MA" output transmitters). After you have calibrated the electrical output of the Gauge and still with no pressure on the diaphragm locate the zero adjust screw on the side of the dial plate and adjust the analogue display to zero. Allow sufficient "soak time" to assure that any material at the transducer tip is molten before extruder drive is started.

### Removal

The Melt Pressure Gauge should only be removed when polymer is hot and liquid. Wipe tip with a soft cloth immediately. The melt pressure Gauge must be removed before using an abrasive material or wire brush to clean the extruder barrel. Clean mounting hole completely before reinstalling the Gauge by using the ONEhalf20 Cleaning Tool Kit, (CLEANKIT-1/2-20).

### Thermocouple Option

ONEhalf20 Melt Pressure Gauge model CTG might also incorporate a thermocouple in the rigid stem (designation -TCJ or -TCK). The standard (-TCJ), Type J (iron-constantan) T/C junction is located just behind the flush diaphragm at the tip of the Gauge. This senses the temperature at that point. The thermocouple assembly can be replaced by loosening the #4-40 cup point set screw on the side of hex assembly and pulling the T/C probe, carefully, straight out, without twisting. Replacement assemblies are available. When installing the thermocouple probe assembly, align the slot with the pressure capillary tube and press into snout until top of probe shoulders flush against snout. Lock in place with set-screw.

### Gauge Repair

Questions concerning warranty, repair cost, delivery, and requests for an RMA# should be directed to the ONEhalf20 Service Department, (416)-781-1881 or by email: [service@onehalf20.com](mailto:service@onehalf20.com). Please call for a return authorization number (RMA#) before returning any product. Damaged Gauges should be returned to:

**ONEhalf20 Inc.**  
**Attn: Service Department**  
**RMA# \_\_\_\_\_**  
**352 Bedford Park Avenue**  
**Toronto, Ontario M5M 1J8**  
**Canada**

[www.onehalf20.com](http://www.onehalf20.com)

Tel: (416) 781-1881

Fax: (416) 781-0940